

Freezer

FCFS201LF B

19.4 Cu. Ft. Commercial,
Food Service Grade



Signature Features

Dynamic Condenser Improves Performance In Higher Temperature Environments

Heavy-Duty, Locking Casters

Heavy-Duty, NSF®-Certified Stainless Steel Shelves

NSF®-Certified For Food Service Applications

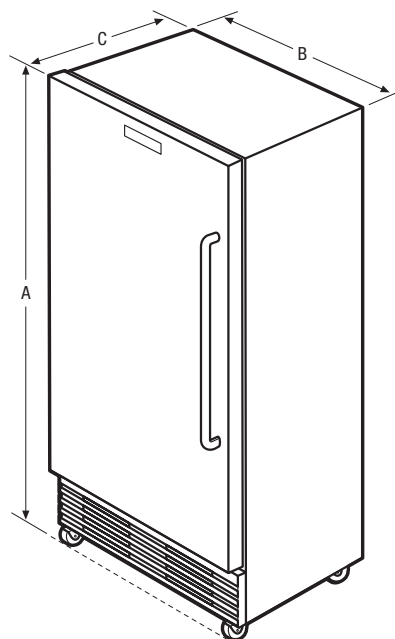

Product Dimensions

| | |
|---|-----------|
| A - Height (Including Hinges & Casters) | 75-13/16" |
| B - Width | 32" |
| C - Depth (Including Door) | 28-5/8" |
| Depth with Door Opened 90° | 59-3/8" |

More Easy-To-Use Features

NSF®-Certified Interior Lighting System

NSF®-Certified Stainless Steel Handle

NSF®-Certified Temperature Gauge

Sealed Cabinet Interior For Easy Cleaning

Stainless Steel Door

Stainless Steel Evaporator Cover

Accessories

| | |
|-------------------------------------|---------------------------|
| Top Shelf - White | 216382202 |
| Deep Shelf - White | 216384002 |
| Trivet - White | 216331802 |
| Shelf Support Clips | 216605300 (4 Required) |
| 18" X 26" Pan Rack Kit ¹ | PANRACKKIT |

Specifications

| | |
|----------------------------------|-------------------|
| Total Capacity (Cu. Ft.) | 19.4 |
| Power Supply Connection Location | Right Bottom Rear |
| Voltage Rating | 120V / 5A |
| Shipping Weight (Approx.) | 273 Lbs. |

ENERGY STAR®

NSF® International Certification



Available in:



Stainless/Black (B)

¹Holds 8 Sheet Pans, Two Kits for Entire Cabinet Length, holds up to Two Kits.

²Stainless Steel Door/Black Cabinet.

Accessories information available on the web at frigidairecommercial.com

